

SE-BAT Lithium-ion Battery

User Manual

50Ah



Solarever Tecnologia de America S.A.de C.V.

Autopista Mexico-Queretaro KM 71.9, S/N Noxtongo Tepeji del
Rio de Ocampo C.P. 42885, Hidalgo Mexico
Tel.: +55 4364 0437
E-mail: contacto@solarever.com.mx

614.00748.00

Copyright Declaration

The copyright of this manual belongs to Solarever Tecnologia de America S.A.de C.V. Any corporation or individual should not plagiarize, partially or fully copy it (including software, etc.), and reproduction or distribution in any form or by any means shall not be allowed. All rights reserved. Solarever Tecnologia de America S.A.de C.V. reserves the right of final interpretation. The information contained herein is subject to change without notice.

www.solarever.com.mx

CONTENTS

1 NOTE ON THIS MANUAL.....	1
1.1 SCOPE OF VALIDITY.....	1
1.2 TARGET GROUP.....	1
1.3 SYMBOLS USED.....	1
2 SAFETY.....	2
2.1 SAFETY INSTRUCTIONS.....	2
2.1.1 GENERAL SAFETY PRECAUTIONS.....	2
2.1.2 EXPLANATION OF SYMBOLS.....	3
2.2 RESPONSE TO EMERGENCY SITUATIONS.....	5
2.2.1 LEAKING BATTERIES.....	5
2.2.2 FIRE.....	5
2.2.3 WET BATTERIES AND DAMAGED BATTERIES.....	5
2.3 QUALIFIED INSTALLER.....	6
3 PRODUCT INTRODUCTION.....	7
3.1 PRODUCT OVERVIEW.....	7
3.1.1 DIMENSION AND WEIGHT.....	7
3.1.2 APPEARANCE.....	8
3.2 BASIC FEATURES.....	10
3.2.1 FEATURES.....	10
3.2.2 CERTIFICATIONS.....	10
3.3 SPECIFICATIONS.....	11
3.3.1 SE-BAT SYS-HV CONFIGURATION LIST.....	11
3.3.2 PERFORMANCE.....	11
4 INSTALLATION.....	12
4.1 INSTALLATION PREREQUISITES.....	12
4.2 SAFETY GEAR.....	12
4.3 TOOLS.....	13
4.4 INSTALLATION.....	13
4.4.1 CHECK FOR TRANSPORT DAMAGE.....	13
4.4.2 UNPACKING.....	13
4.4.3 ACCESSORIES.....	14
4.4.4 BATTERY INSTALLATION STEPS.....	16

4.5 OVERALL INSTALLATION.....	18
4.5.1 CABLE CONNECTION.....	20
4.5.2 CONNECTING POWER CABLES.....	22
4.5.3 CONNECTING POWER LINES.....	26
4.5.4 CONNECTING CAN COMMUNICATION CABLE.....	27
4.5.5 CONNECTING RS485 COMMUNICATION CABLE.....	28
4.5.6 CONNECTING GROUND WIRE.....	29
4.6 OVERVIEW OF INSTALLATION.....	31
5 COMMISSIONING.....	32
5.1 CONFIGURING BATTERY SYSTEM.....	32
5.2 COMMISSIONING.....	33
5.3 STATUS INDICATORS.....	35
5.3.1 BMS	35
5.3.2 BATTERY PACK.....	36
5.4 SHUTTING DOWN SE-BAT SYSTEM.....	36
6 TROUBLESHOOTING.....	37
6.1 TROUBLE SHOOTING.....	37
7 DECOMMISSIONING.....	40
7.1 DISMANTLING THE BATTERY.....	40
7.2 PACKAGING.....	40
8 MAINTENANCE AND WARRANTY.....	41

1 Note on this Manual

1.1 Scope of Validity

This manual is an integral part of SE-BAT Series. It describes the assembly, installation, commissioning, maintenance and failure of the product. Please read it carefully before operating.

SE-BAT SYS-HV

SE-BAT-MA H 5.8

SE-BAT PACK-HV

SE-BAT-SL H 5.8

NOTE: There are 4 models for SE-BAT system, which includes BMS and battery pack(s). Please refer to section 3.3.1 SE-BAT SYS-HV Configuration List on page 11 for detailed models.

1.2 Target Group

This manual is for qualified electricians. The tasks described in this manual may only be performed by qualified electricians.

1.3 Symbols Used

The following types of safety instructions and general information appear in this document described as below:



DANGER!

“DANGER” indicates a hazardous situation which, if not avoided, will result in death or serious injury.



WARNING!

“WARNING” indicates a hazardous situation which, if not avoided, could result in death or serious injury.



CAUTION!

“CAUTION” indicates a hazardous situation which, if not avoided, could result in minor or moderate injury.



NOTE!

“NOTE” provides tips that are valuable for the optimal operation of your product.

2 Safety

2.1 Safety Instructions

For safety reasons, installers are responsible for familiarizing themselves with the contents of this manual and all warnings before performing installation.

2.1.1 General Safety Precautions

⚠ WARNING!

Please don't crush or impact the battery, and always dispose it according to the safety regulation.

Observe the following precautions:

- Risks of explosion
 - Do not subject the battery pack to strong impacts.
 - Do not crush or puncture the battery pack.
 - Do not dispose of the battery pack in a fire.
- Risks of fire
 - Do not expose the battery pack to temperatures in excess of 131°F /55°C.
 - Do not place the battery pack near a heat source, such as a fireplace.
 - Do not expose the battery pack to direct sunlight.
 - Do not allow the battery connectors to touch conductive objects such as wires.
- Risks of electric shock
 - Do not disassemble the battery pack.
 - Do not touch the battery pack with wet hands.
 - Do not expose the battery pack to moisture or liquids.
 - Keep the battery pack away from children and animals.
- Risks of damage to the battery pack
 - Do not allow the battery pack to get in contact with liquids.
 - Do not subject the battery pack to high pressures.
 - Do not place any objects on top of the battery pack.

SE-BAT SYS-HV can be used only in the household energy field it is not allowed to be used in other industries, such as the medical equipment and automotive application.





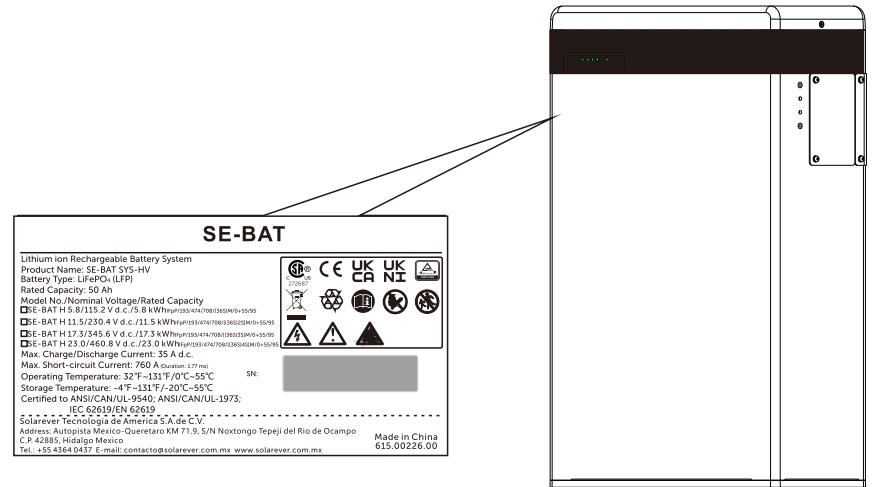







2.1.2 Explanation of Symbols

This section gives an explanation of all the symbols shown on the SE-BAT system and on the warning label.



⚠ CAUTION!

If the battery is not installed within one month after receiving the battery, the battery must be charged till the SOC is more than 50% for maintenance.

Symbol	Explanation
	The PV inverter is compliant with TUV
	CE mark. The inverter complies with the requirements of the applicable CE guidelines.
	CSA certified
	The battery system should be disposed of at a proper facility for environmentally safe recycling.
	The battery system should not be disposed together with the household waste. Disposal information can be found in the enclosed documentation.
	Wear protective glasses
	Observe enclosed documentation.
	Keep the battery system away from open flames or ignition sources.
	Keep the battery system away from children.
	Danger of high voltages. Danger to life due to high voltages in the battery system!
	Danger. Risk of electric shock!
	The battery pack may explode.

2.2 Response to Emergency Situations

2.2.1 Leaking Batteries

If the battery leaks electrolyte which is corrosive, avoid contact with the leaking liquid or gas. Direct contact may lead to skin irritation or chemical burns. If one is exposed to the leaked substance, do these actions:

Accidental inhalation of harmful substances: Evacuate people from the contaminated area, and seek medical attention immediately.

Eye contact: Rinse eyes with flowing water for 15 minutes, and seek medical attention immediately.

Dermal contact: Wash the affected area thoroughly with soap and water, and seek medical attention immediately.

Ingestion: Induce vomiting, and seek medical attention immediately.

2.2.2 Fire

In case of a fire, make sure an ABC or carbon dioxide extinguisher is nearby.



WARNING!

The battery pack may catch fire when heated above 302°F / 150°C.

If a fire breaks out where the battery pack is installed, do these actions:

1. Extinguish the fire before the battery pack catches fire;
2. If the battery pack has caught fire, do not try to extinguish the fire. Evacuate people immediately.

WARNING!

If the battery pack catches fire, it will produce noxious and poisonous gases. Do not approach.

2.2.3 Wet Batteries and Damaged Batteries

If the battery pack is wet or submerged in water, do not try to access it.

If the battery pack seems to be damaged, they are not fit for use and may pose a danger to people or property.

Please pack the battery in its original container, and then return it to Solarever or your distributor.

CAUTION!

Damaged batteries may leak electrolyte or produce flammable gas. If you suspect such damage, immediately contact Solarever for advice and information.

2.3 Qualified Installer

! WARNING!

All operations of SE-BAT SYS-HV relating to electrical connection and installation must be carried out by qualified personnel.

A skilled worker is defined as a trained and qualified electrician or installer who has all of the following skills and experience:

- Knowledge of the functional principles and operation of on-grid systems
- Knowledge of the dangers and risks associated with installing and using electrical devices and acceptable mitigation methods
- Knowledge of the installation of electrical devices
- Knowledge of and adherence to this manual and all safety precautions and best practices

3 Product Introduction

3.1 Product Overview

For safety reasons, installers are responsible for familiarizing themselves with the contents of this manual and all warnings before performing installation.

3.1.1 Dimension and Weight

A battery management system (BMS) is any electronic system that manages a rechargeable battery.

Battery pack is a type of electrical battery which can be charged, discharged into a load.

A battery system includes BMS and battery pack(s).

	SE-BAT-MA H 5.8	SE-BAT-SL H 5.8
Length	18.66 in/474.00 mm	18.66 in/474.00 mm
Width	7.60 in/193.00 mm	7.60 in/193.00 mm
Height	27.87 in/708.00 mm	25.47 in/647.00 mm
Weight	159.2 lbs/72.2 kg	151.0 lbs/68.5 kg

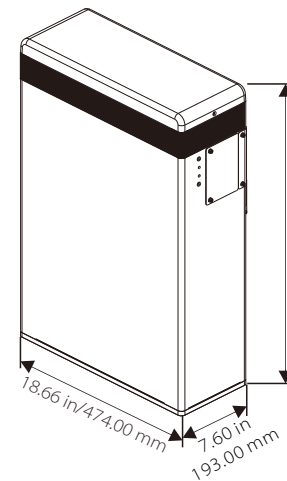

SE-BAT-MA H 5.8

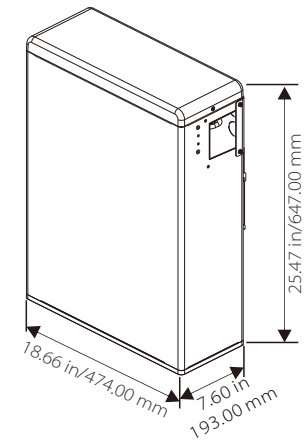

SE-BAT-SL H 5.8
(Battery Pack)

3.1.2 Appearance

- Section view of SE-BAT-MA H 5.8

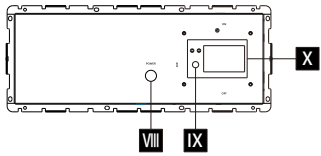
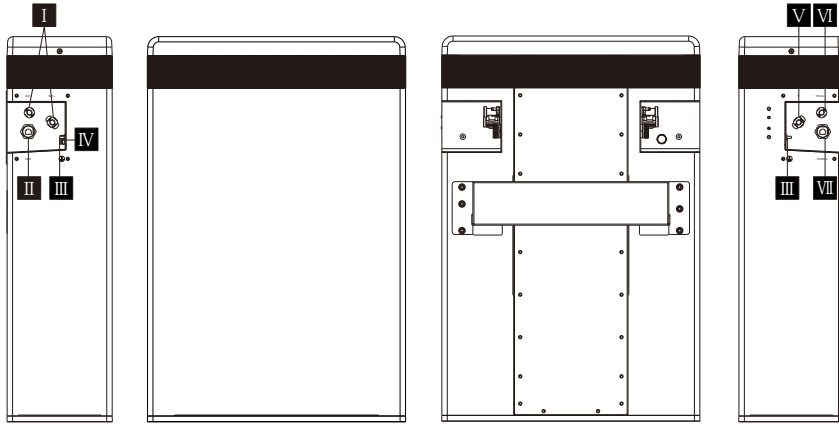

Object	Mark	Description
I	BAT+/BAT-	Charge/Discharge Connectors
II	CAN	CAN Connector
III	GND	GND
IV	/	Air Valve
V	—	Power Connector to + of next battery pack, or to YPLUG of the same pack
VI	YPLUG	Power Connector' to XPLUG of next battery pack, or to "-" of the same pack
VII	RS485 II	RS485 Connector to RS485 I of next battery pack
VIII	POWER	Power Button
IX	DIP	DIP Switch
X	ON/OFF	Circuit Breaker

- Section view of SE-BAT-SL H 5.8

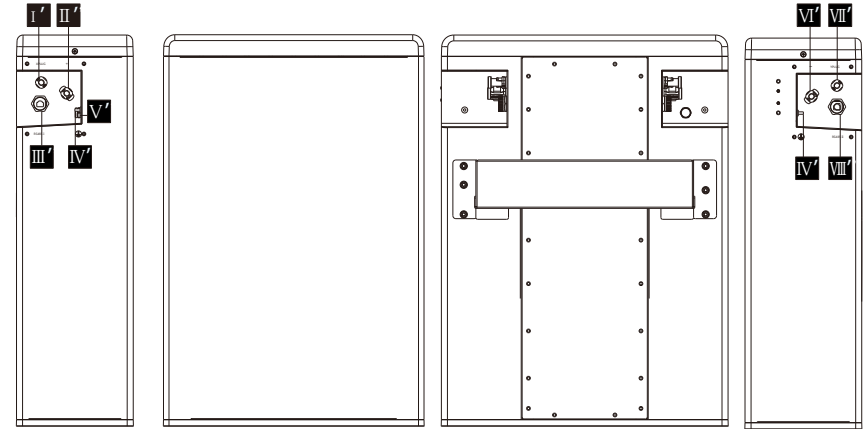

Object	Mark	Description
I'	XPLUG	Power Connector' to YPLUG of upper battery pack
II'	+	Power Connector to "-" of upper battery pack
III'	RS485 I	RS485 Connector to RS485 II of upper battery pack
IV'	GND	GND
V'	/	Air valve
VI'	—	Power Connector to + of next battery pack, or to YPLUG of the same pack
VII'	YPLUG	Power Connector' to XPLUG of next battery pack, or to "-" of the same pack
VIII'	RS485 II	RS485 Connector to RS485 I of next battery pack

3.2 Basic Features

3.2.1 Features

The SE-BAT SYS-HV is one of the advanced energy storage systems on the market today, incorporating state-of-the-art technology, high reliability, and convenient control features shown as below:

- 90% DOD
- 99% Faradic charge efficiency
- 95% Battery roundtrip efficiency
- Cycle life > 6000 times
- Secondary Protection by hardware
- IP55 protection level
- Safety & Reliability
- Small footprint
- Floor or wall mounting

3.2.2 Certifications

SE-BAT system safety	CE, FCC, RCM, TUV (IEC 62619), UL 1973
Battery cell safety	UL 1642
UN number	UN 3480
Hazardous materials classification	Class 9
UN transportation testing requirements	UN 38.3
International protection marking	IP 55

3.3 Specifications

3.3.1 SE-BAT SYS-HV Configuration List

No.	Model	Battery Pack	Energy(kWh)	Voltage (V)
1	SE-BAT H 5.8	SE-BAT-MA H 5.8*1	5.8	100-131
2	SE-BAT H 11.5	SE-BAT-MA H 5.8*1+SE-BAT-SL H 5.8*1	11.5	200-262
3	SE-BAT H 17.3	SE-BAT-MA H 5.8*1+SE-BAT-SL H 5.8*2	17.3	300-393

3.3.2 Performance

	SE-BAT-MA H 5.8	SE-BAT-SL H 5.8
Dimension (in/mm)	18.66*7.60*27.87 474.00*193.00*708.00	18.66*7.60*25.47 474.00*193.00*647.00
Weight (kg)	72.2	68.5
Nominal Voltage (V d.c.)	115.2	115.2
Operating Voltage (V d.c.):	100-131	100-131
Nominal Capacity (Ah)	50	50
Nominal Energy (kWh) : ❶	5.8	5.8
Usable Energy (kWh) : ❷	5.2	5.2
Max. Charge/Discharge Current (A d.c.) : ❸	35	35
Recommend Charge/Discharge Current (A d.c.):	25	25
Standard Power (kW)	2.9	2.9
Maximum Power (kW)	4.0	4.0
Altitude (m)	≤ 2000	
Faradic Charge Efficiency (25°C/77°F)	99%	
Battery Roundtrip Efficiency (C/3,25°C/77°F)	95%	
Expected Lifetime (25°C/77°F)	10 years	
Cycle Life (90% DOD, 25°C/77°F)	6000 cycles	
Available Operating Temperature	32°F~131°F/0°C~55°C	
Optimal Operating Temperature	59°F~95°F/15°C~35°C	
Storage Temperature	-4°F~131°F/-20°C~55°C (3 months)	
	32°F~104°F/0°C~40°C (1 year)	
Ingress Protection	IP55	

❶ Test conditions: 100% DOD, 0.5C charge & discharge @+25°C

❷ 90% DOD; System usable energy may vary with inverter different setting

❸ Discharging: 32°F~41°F/0°C~5°C and 113°F~131°F/45-55°C will be rating
Charging: 32°F~41°F/0°C~5°C and 104°F~122°F/40°C~50°C will be rating

4 Installation

4.1 Installation Prerequisites

Make sure that the installation location meets the following conditions:

- The building is designed to withstand earthquakes
- The location is far away from the sea, to avoid salt water and humidity
- The floor is flat and level
- There are no flammable or explosive materials nearby
- The ambience is shady and cool, keep away from heat and avoid direct sunlight.
- The temperature and humidity stays at a constant level.
- There is minimal dust and dirt in the area.
- There is no corrosive gases present, including ammonia and acid vapor.
- The ambient temperature is within the range from 32°F/0°C to 113°F/45°C, and the optimal ambient temperature is between 9°F/15°C and 95°F/35°C.

NOTE!

The SE-BAT battery pack is rated at IP55 and thus can be installed outdoors as well as indoors. However, if installed outdoors, do not allow the battery pack to be exposed to direct sunlight and moisture.

NOTE!

If the ambient temperature is outside the operating range, the battery pack stops operating to protect itself. The optimal temperature range for the battery pack to operate is 15°C to 35°C. Frequent exposure to harsh temperatures may deteriorate the performance and lifetime of the battery pack.

4.2 Safety Gear

Installation and maintenance personnel must operate according to applicable federal, state and local regulations as well as the industry standards regarding the product installation personnel shall wear safety gears, etc. in order to avoid short circuit and personal injury.



Insulated gloves



Safety goggles



Safety shoes

4.3 Tools

These tools are required to install the SE-BAT system.



Torque screw driver



Phillips-screw driver



Socket nut wrench



Phillips-head screw driver



Flat-head screw driver



Torque wrench

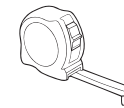

Tape measure



Drill



Pencil or Marker

4.4 Installation

4.4.1 Check for Transport Damage

Make sure the battery is intact during transportation. If there are some visible damages, such as cracks, please contact your dealer immediately.

4.4.2 Unpacking

Unpacking the battery package by cutting the packing tape and make sure the battery packs and the relevant items are complete. See package items on section 4.4.3, please check the packing list carefully, if there's any item missing, please contact Solarever or your distributor directly.

CAUTION!

According to regional regulations, several people may be required for moving equipment.

WARNING!

Please strictly follow the installation steps. Solarever will not answer for any hurting or loss arising by incorrectly assembling and operation.

4.4.3 Accessories

SE-BAT-MA H 5.8:

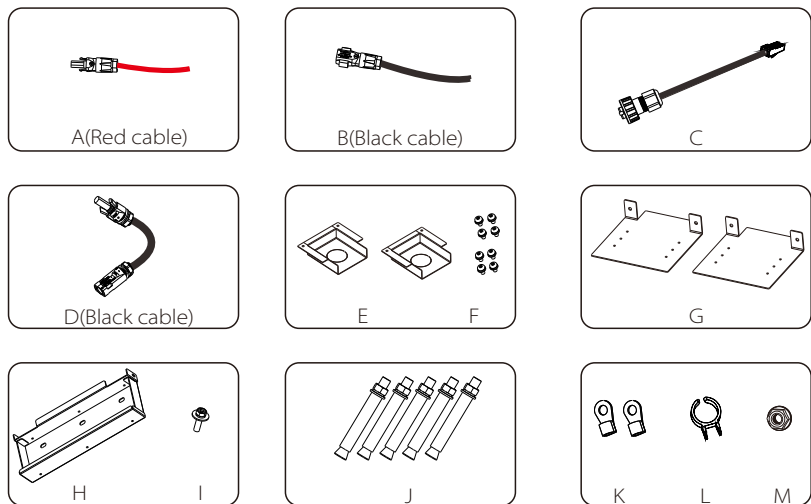

The table below lists the number of each component.

Object	Description	Quantity
A	Power line between Inverter and SE-BAT-MA H 5.8 (+) (6.56 ft/2.00 m)	1
B	Power line between Inverter and SE-BAT-MA H 5.8 (-) (6.56 ft/2.00 m)	1
C	CAN communication cable (6.56 ft/2.00 m)	1
D	Series-connected plug	1
E	Cover plate2	2
F	M4 screw	8
G	Cover plate2	2
H	Wall bracket	1
I	M5 screw	1
J	Expansion bolt	5
K	Ring terminal (for grounding)	2
L	Power cable disassembling tool	1
M	Grounding nut	2

SE-BAT-SL H 5.8:

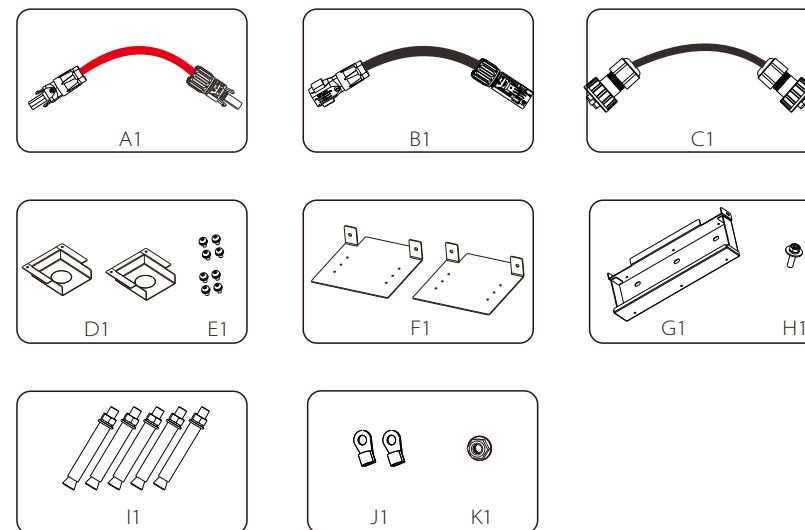

The table below lists the number of each component.

Object	Description	Quantity
A1	Power cable between battery packs (259.59 in/650.00 mm)	1
B1	Power cable between battery packs (259.59 in/650.00 mm)	1
C1	Rs485 communication cable (259.59 in/650.00 mm)	1
D1	Cover plate2	2
E1	M4 screw	8
F1	Cover plate2	2
G1	Wall bracket	1
H1	M5 screw	1
I1	Expansion bolt	5
J1	Ring terminal (for grounding)	2
K1	Grounding nut	2

4.4.4 Battery Installation Steps

It is recommended that the space between battery packs is more than 300mm.

Steps (for SE-BAT-MA H 5.8 or SE-BAT-SL H 5.8):

Make sure the wall is strong enough to withstand the weight of battery packs.

Step 1: fix the wall bracket (H or G1) on the wall

- Use the wall bracket as a template to mark the position of the 5 holes
- Drill holes with \varnothing 0.39 in/10 mm drill, make sure the holes are deep enough (at least 80mm) for installing and tightening the expansion bolts (J or I1)
- Install the expansion bolts in the wall, and screw the bracket by using the wrench.

Step 2: Match the battery with the wall bracket

- Transport the battery to the wall bracket
- Hang the battery over the wall bracket, move the battery close to it, and match it on the wall bracket

Step 3: Lock the joint between hanging board and wall bracket with M5 combinationscrew (I or H1).

Note: 1. Keep the distance from installation point to the floor less than 259.59 in/650.00 mm.

2. It is recommended to keep a distance of 32.44 in/824.00 mm between the center of wall bracket and the wall bracket.

3. It is recommended to keep a distance of 13.78 in/350.00 mm between battery packs, Must be between 12.60~14.96 in/320.00 ~380.00 mm.

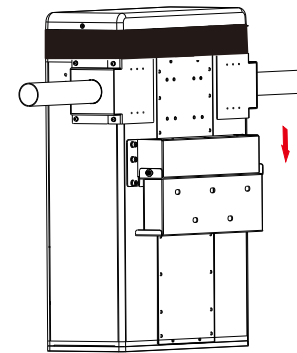
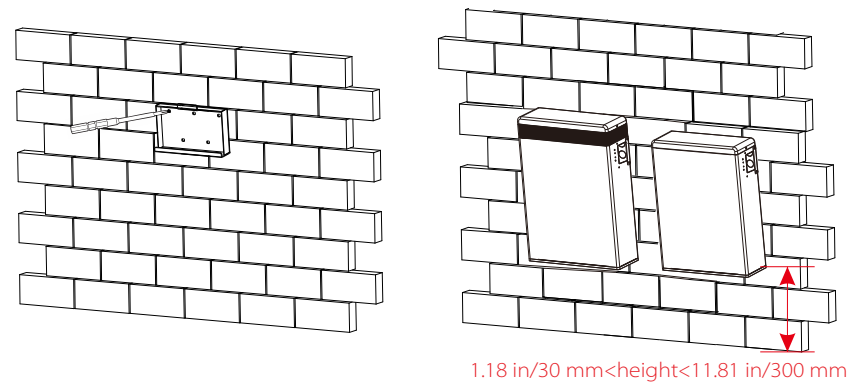
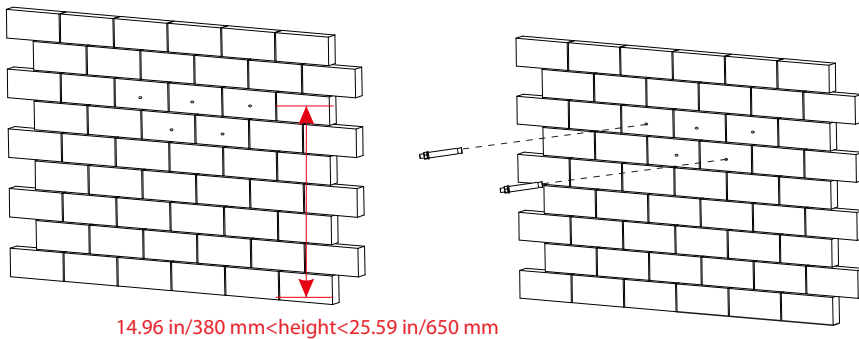

Side view of hanging the battery to the wall bracket.

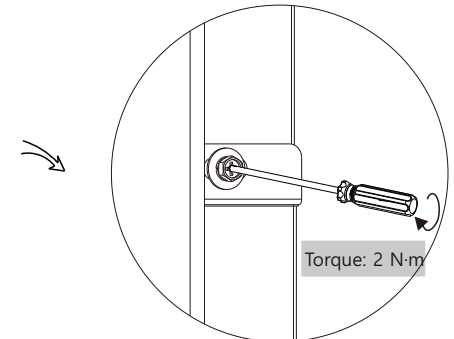
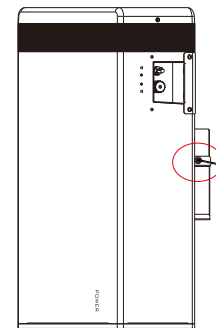

4.5 Overall Installation

It is recommended to protect the cables by using corrugated pipe.

For SE-BAT-MA H 5.8:

1. Connect all the cables on the left side of SE-BAT-MA H 5.8.
2. Install cover plates and conduits. Install cover plate and conduit. Pass the conduits(A1) and joint(A2) through the round hole of the cover plate(A3) and tighten it with the Hexagon flange head screw(A4). These conduits must be standard size and match the holes in the battery cover plate. The catheter fittings must be waterproof and preferably insulated. (conduit size: 1-1/1 in/12.7-12.7 mm)
3. Get the cables through the conduit .
4. Finally, screw the front and side cover plates onto the battery.(torque:2N.M)
5. DO remember to insert the series-connected plug at "-" and "YPLUG" on the right side of SE-BAT-MA H 5.8 to make a complete circuit.
6. Set the cables into the groove of metal plates and screw them back to the battery pack on both sides.

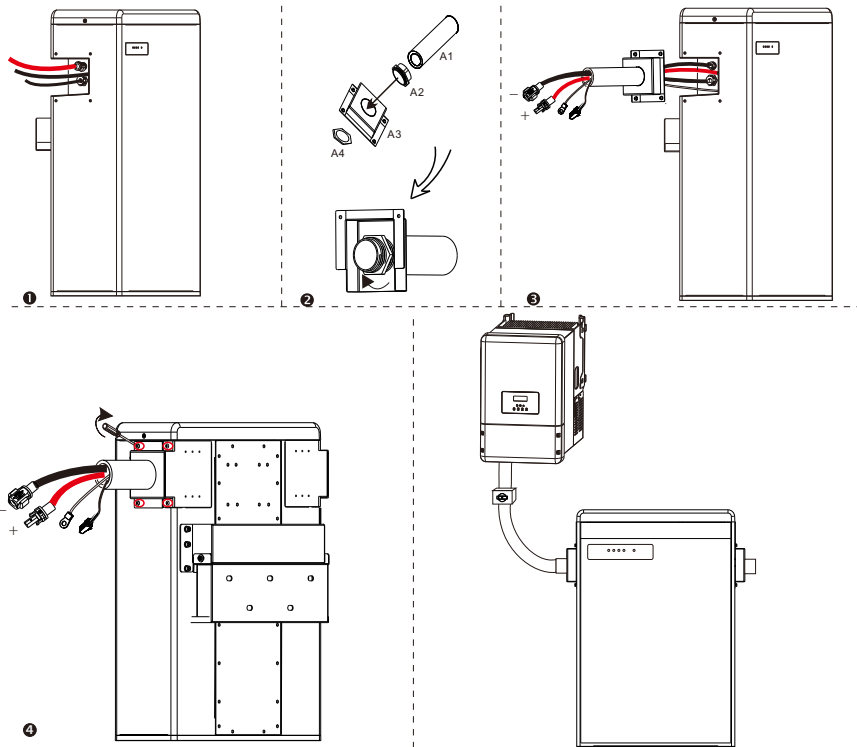

For SE-BAT-MA H 5.8 + 1~3 battery packs:

1. Connect the cables at one end of the SE-BAT-MA H 5.8/SE-BAT-SL H 5.8.
2. Get the cables through the conduit. (conduit size: 1-1/2 in/12.7~25.4 mm) (please refer to section 4.5 For SE-BAT-MA H 5.8 step 2)
3. Finally, screw the front and side cover plates onto the battery.(torque:2N.M)
4. DO remember to insert the series-connected plug at "-" and "YPLUG" on the right side of last battery pack to make a complete circuit.

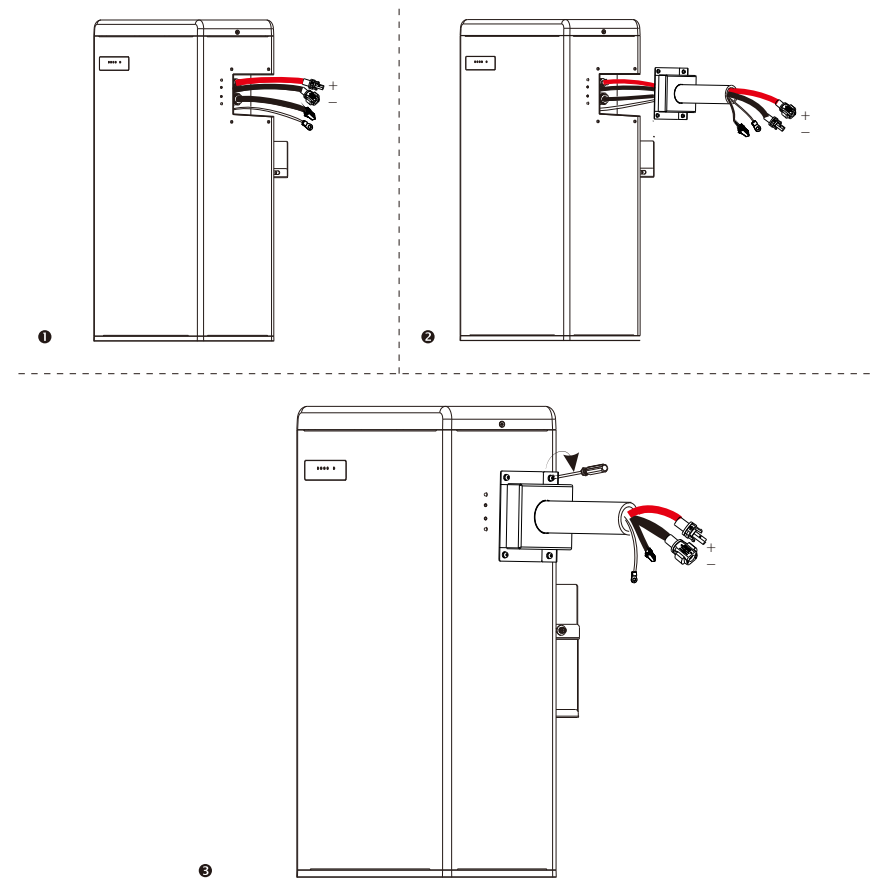

4.5.1 Cable Connection

Please refer to section 4.5 for the installation of conduit and cover plate, and then make connection.

On the left side of SE-BAT-MA H 5.8 , after the charging cables (please refer to section 4.5.2) and CAN communication cable (please refer to section 4.5.4) are correctly connected, screw the terminal box_small (J) with M4 screws and lock the terminal box cover (K) also with M4 screws.

On the right side of SE-BAT-MA H 5.8 , after the battery modules (please refer to section 4.5.1 For 2~3 battery modules) are correctly ,screw the terminal box_medium_right (I1) with M4 screws and lock the terminal box cover (K1) in the same way as BMS.

Please see the installation diagram on the right. (screw torque: 2 N·m)

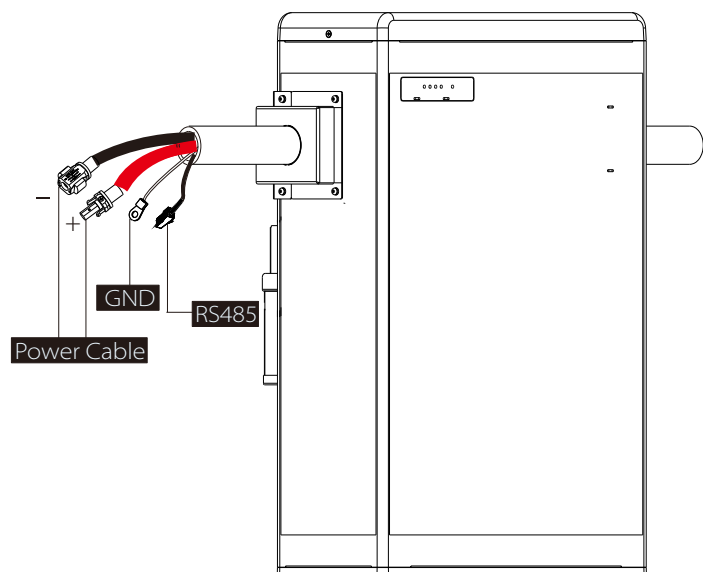

For 2~3 battery modules:

The power cable between battery modules (A1) is different from the one that between BMS and battery module (C). The other end of the power cable is black, and this color is connected to YPLG (V'), which is on the right side of the battery module.

1. Connect YPLUG (V') on the right side of battery module to XPLUG (I') on the left side of the second battery module. The rest battery modules are connected in the same way. The following figure shows that four battery modules are connected.

2. Before connecting the cables to XPLUG (I') on the left side of follow-up battery module, lock the terminal box_medium_right(I1) on the right side of previous battery module with M4 screws(H1), and get the cables through the conduits which length is 7.87~9.45 in/200.00~240.00 mm, then lock the terminal box cover (K1) with M4 screws.

3. Lock the terminal box_medium_left(J1) on the left side of follow-up battery module, and keep the terminal box cover (K1) unlocked until the cables are correctly connected to the YPLUG.

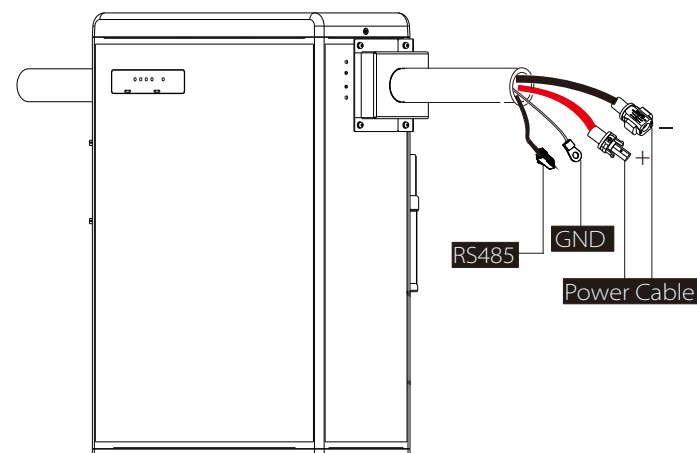

4.5.2 Connecting Power Cables

For SE-BAT-MA H 5.8:

1. The only step of connecting power cable for SE-BAT-MA H 5.8 is connecting the series-connected plug to "-" and "YPLUG" on the right side. The series-connected plug is used to make a complete circuit.

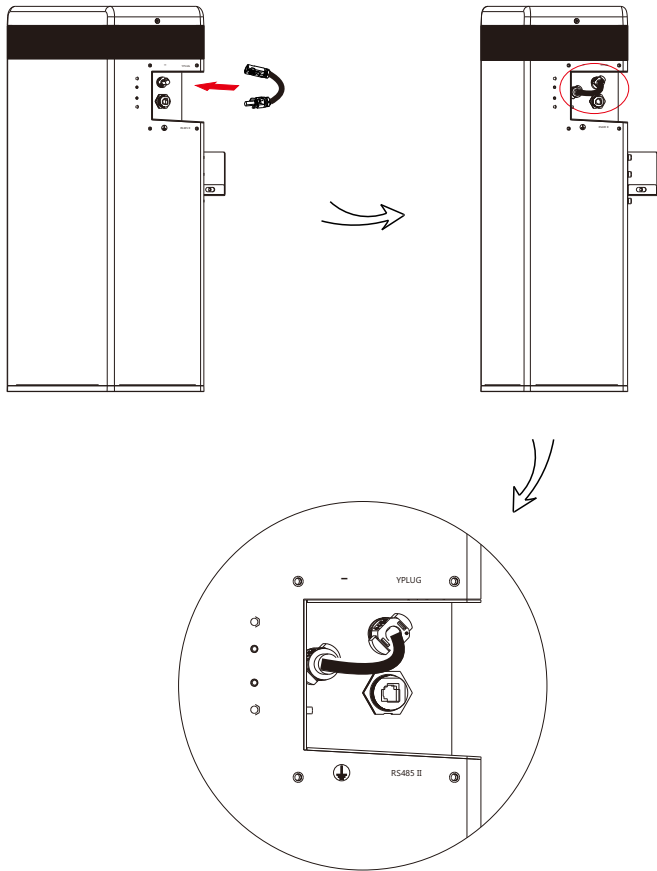

For SE-BAT-MA H 5.8 + 1~3 battery packs:

1. Connect "-" (V for SE-BAT-MA H 5.8 or VI for SE-BAT-SL H 5.8) on the right side to "+" (II') on the left side of the next battery pack.
2. Connect "YPLUG" (VI for SE-BAT-MA H 5.8 or VII for SE-BAT-SL H 5.8) on the right side to "XPLUG" (I') on the left side of the next battery pack.
3. The rest battery packs are connected in the same way.
4. Insert the series-connected plug at "-" and "YPLUG" on the right side of last battery pack to make a complete circuit.

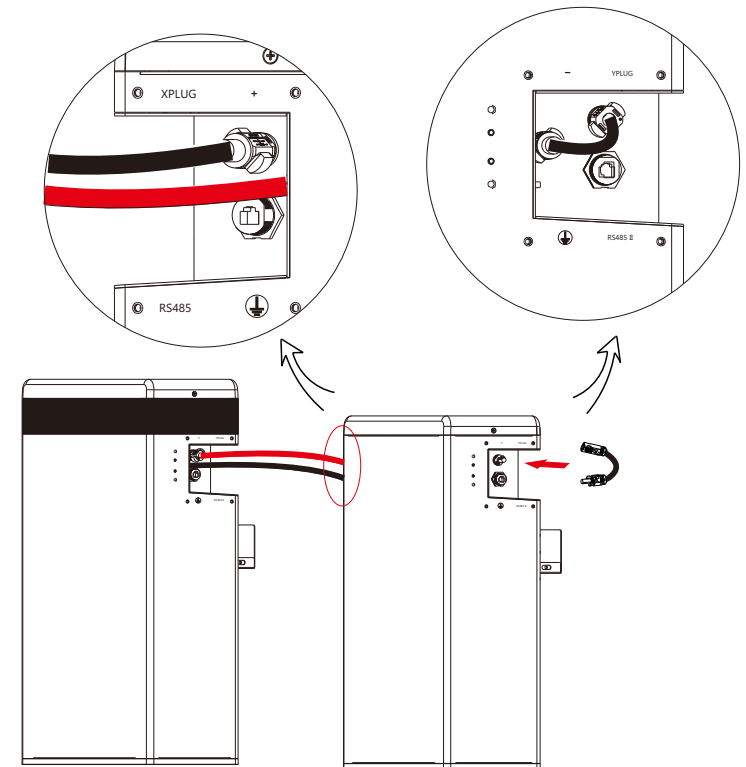

4.5.3 Connecting Power Lines

This step is going to connect power lines between Inverter and SE-BAT system.

The default length of power lines are 6.56 feet/2 meters, so customers can properly cut the cable according to the actual installation environment. As a result, each power line has one terminal block when leaving the factory, and customers need to connect the other end of terminal block by themselves.

➤ **Connecting Charging Cables between Inverter and SE-BAT system:**

1. Connect the positive cable (+)(A) and negative cable (-)(B) through the accessory Cover plate1 to the corresponding port as shown in the following figure.

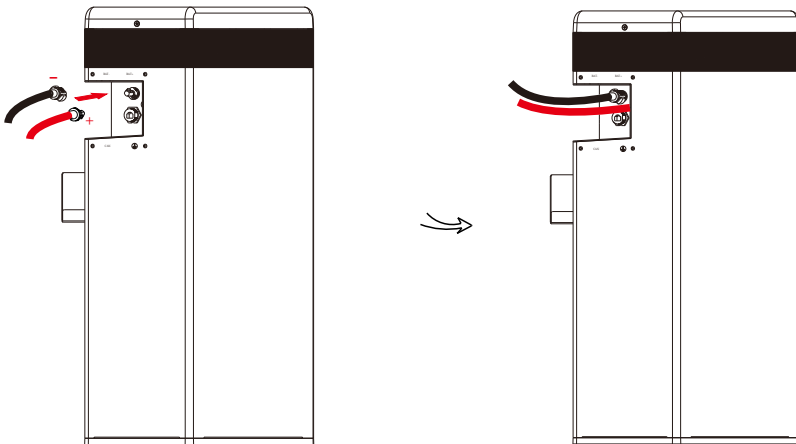

3. Pass the other end of the charging cable through the inverter's pipe. Insert the trip head of each wire into the hole.

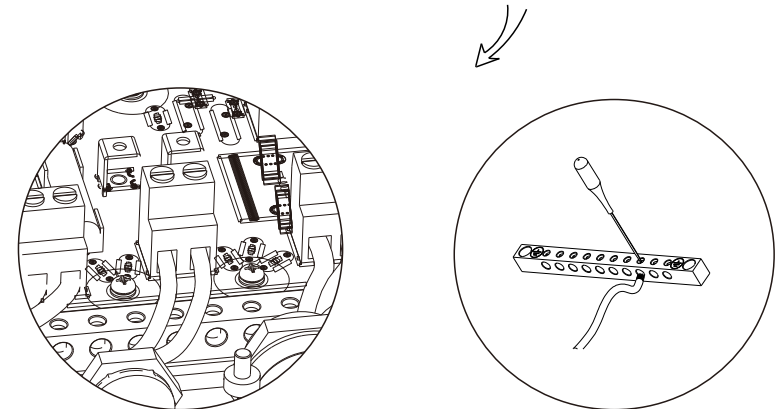
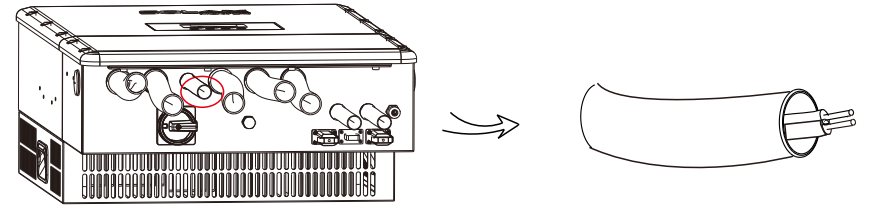

Charging cables

GND

NOTE!

1. When connecting the cable to SE-BAT-MA H 5.8, fit the two connectors together until the connection audibly locks into place.
2. Check to make sure the connection is securely locked.
3. Don't shake both ends of the cable at the joint once the connection is locked.

➤ Disassembling Power Line (on BAT+, BAT-, "+", XPLUG port)

Disassemble the power line by plugging the slot type screwdriver to the terminal groove of charging cable. Please see the illustration as shown below:

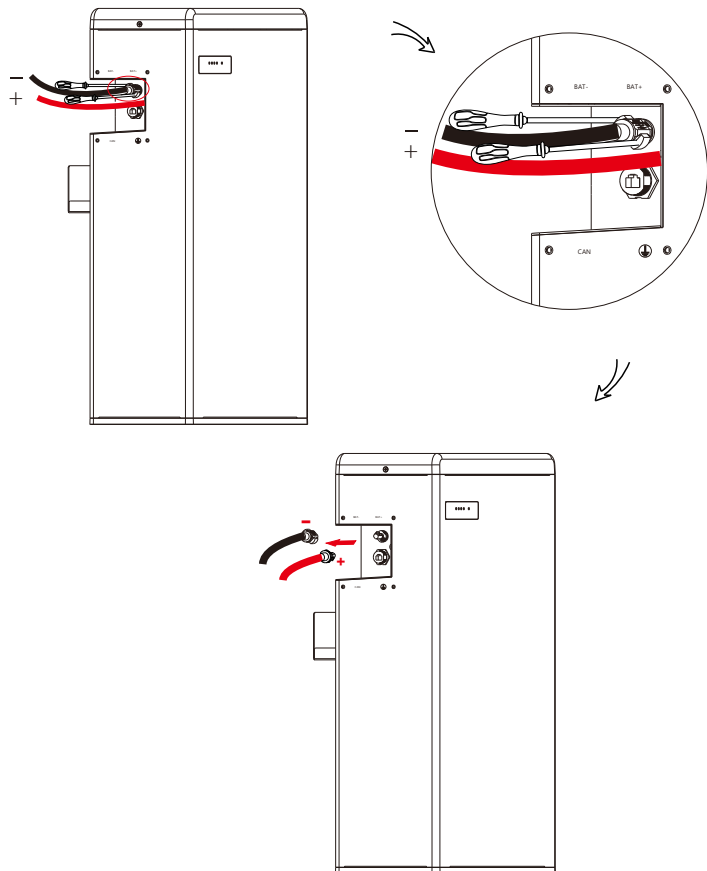

⚠ CAUTION!

DO NOT disassemble power cables when the SE-BAT system is not turned off, otherwise there will be an arc discharge that could cause serious injury!

➤ Disassembling Power Cable (on "-", YPLUG port)

Disassemble the power line by plugging the Power cable disassembling tool(L) to the terminal groove of charging cable. Please see the illustration as shown below:

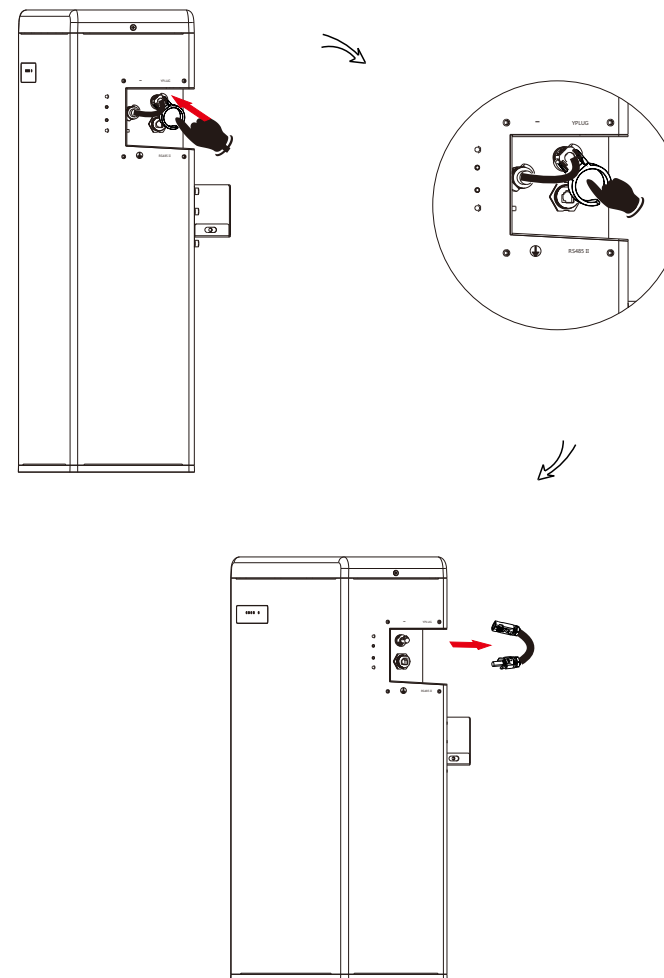

4.5.4 Connecting CAN Communication Cable

It is required for the BMS to communicate with the inverter for proper operation.

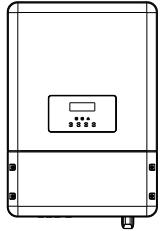

1. Insert one end of the CAN communication cable (C) which has no cable nut directly to the BMS port of the Inverter.

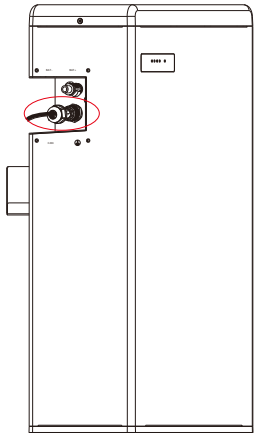

2. Connect the CAN communication cable to the CAN connector (II) which is marked in red. Insert the other end of the CAN communication cable to the CAN connector. Assemble the cable gland and screw the cable nut.

The wire order of the communication cable is as follows:

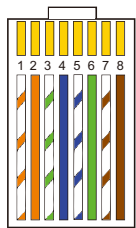
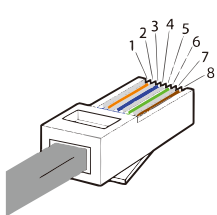

- 1) White with an orange stripe
- 2) Orange
- 3) White with a green stripe
- 4) Blue
- 5) White with a blue stripe
- 6) Green
- 7) White with a brown stripe
- 8) Brown

Sequence	1	2	3	4	5	6	7	8
CAN	/	GND	/	CAN_H	CAN_L	/	A1	B1

4.5.5 Connecting RS485 Communication Cable

For SE-BAT-MA H 5.8:

There's no need to use RS485 communication cable.

For SE-BAT-MA H 5.8 + 1~3 battery packs:

Connect RS485 II (VII for SE-BAT-MA H 5.8 or VIII for SE-BAT-SL H 5.8) of upper battery on the right side to RS485 I (III) of the follow-up battery pack which is on the left. Assemble the cable gland and screw the cable nut.

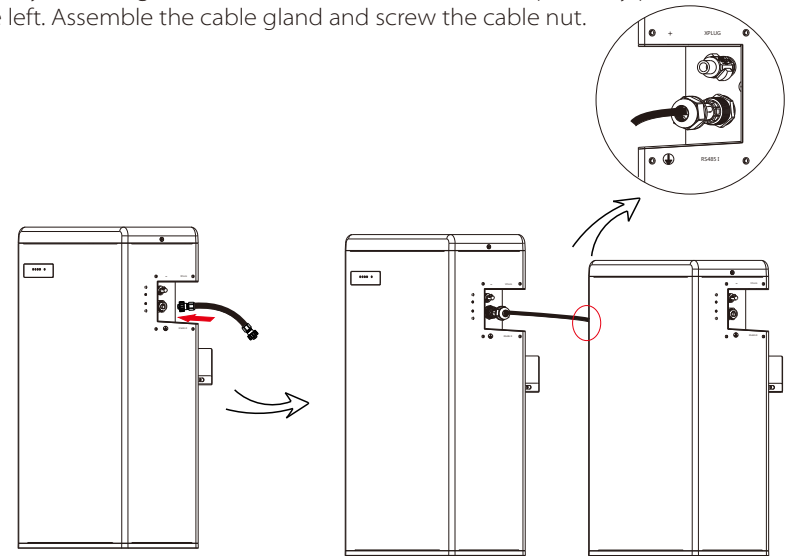

The wire order of the communication cable is as follows:

Sequence	1	2	3	4	5	6	7	8
RS485I	VCC_485	GND_485	B2	N-	P+	A2	VCC_485_2	GND_485
RS485II	VCC_485	GND_485	B2	N-	P+	A2	VCC_485_2	GND_485

4.5.6 Connecting Ground Wire

The terminal point for GND connection is on the side of grooves as shown below (torque: 1.5 N·m):

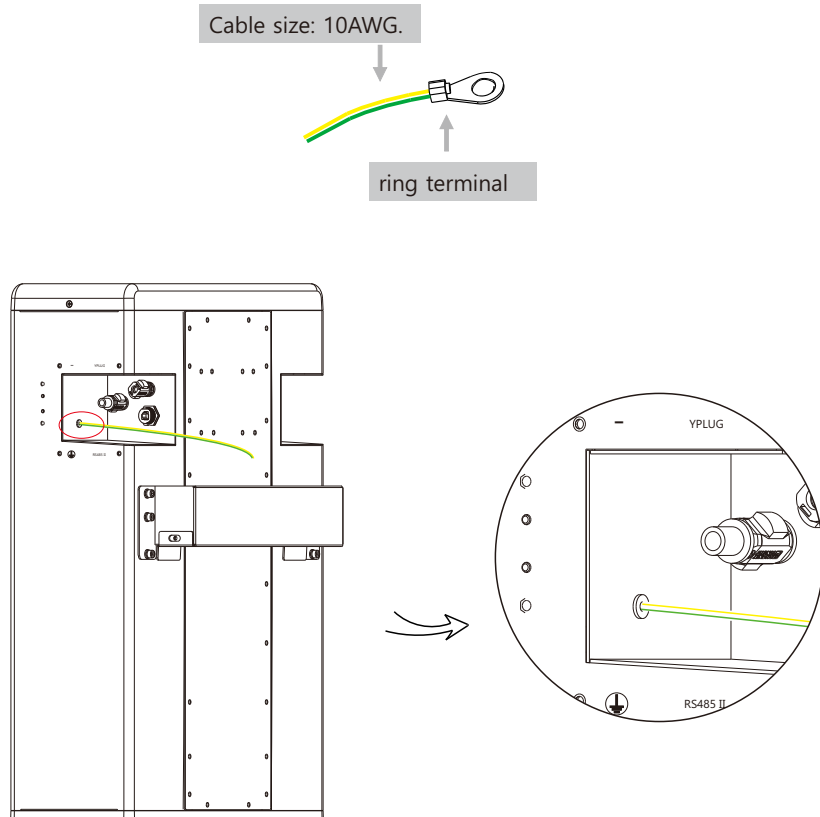

CAUTION!
GND is mandatory!

4.6 Overview of Installation

The following diagram is a complete SE-BAT system installation with SE-BAT-MA H 5.8 + three battery packs.

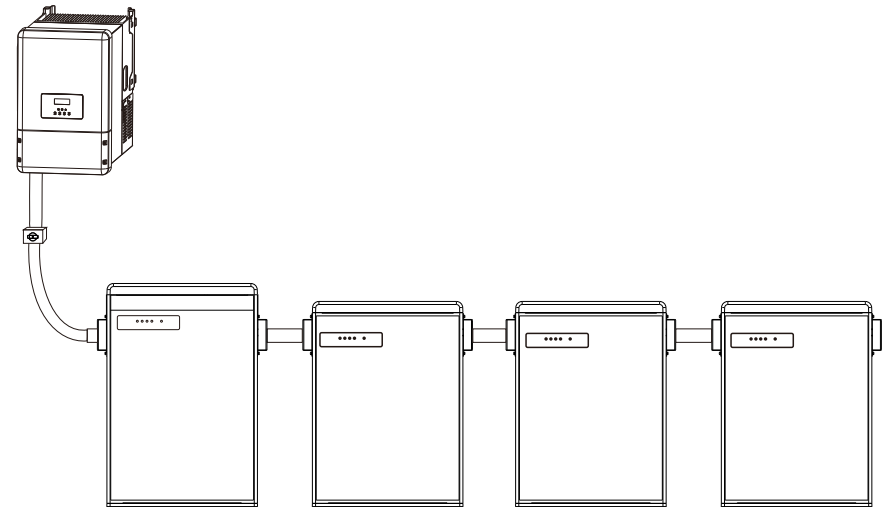

CAUTION!
One SE-BAT system is allowed to install one SE-BAT-MA H 5.8 plus at most three battery packs. Connecting more than three battery packs will blow the fuse, and the battery pack will be damaged. Please make sure the number of battery packs meets the requirement.

5 Commissioning

5.1 Configuring Battery System

The DIP switch is used to configure the number of battery packs which are communicating to Inverter. The detailed configuration information is shown as follows:

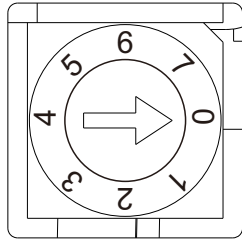

Configuration activated by inverters

- 0- Matching SE-BAT-MA H 5.8 (default)
- 1- Matching SE-BAT-MA H 5.8 + 1*SE-BAT-SL H 5.8
- 2- Matching SE-BAT-MA H 5.8 + 2*SE-BAT-SL H 5.8

➤ Black-start configuration

The black-start function is only used in the off-grid environment and there is no other power supply.

Note: if the battery is started in black-start mode, although there is no BMS communication, the port still has high voltage and there is a risk of electric shock!

After the black-start mode is started, if the BMS communication has still not been built within 3 minutes, the black start fails.

- 4- Matching SE-BAT-MA H 5.8
- 5- Matching SE-BAT-MA H 5.8 + 1*SE-BAT-SL H 5.8
- 6- Matching SE-BAT-MA H 5.8 + 2*SE-BAT-SL H 5.8

5.2 Commissioning

👉 NOTE!

When powering on the BMS, the system will start self-testing. If the buzzer bips, it means DIP configuration fault or communication failure occurs. If the buzzer bips, please check if the number of battery packs is corresponding to the DIP configuration, and also check if the RS485 communication cables are correctly connected. After these two situations are checked OK, press the POWER button to power on, and press the POWER button again 10s later. In addition: The buzzer will only alarm on the corresponding fault during the power-on self-test. After the self-test is completed, it won't bip again even if the same fault occurs.

👉 NOTE!

Frequently pressing the POWER button may cause the system error. Please make sure at least 10 seconds is needed when you are going to press the POWER button from the last pressing operation.

Commissioning Steps

If all the battery packs are installed, follow these steps to put it in operation.

1. Remove the upper cover board of SE-BAT-MA H 5.8;
2. Remove the small cover plate;
3. Rotate the DIP to corresponding number with small tool according to the number of battery pack(s) that has(have) been installed;
4. Move the circuit breaker to the ON position;
5. Press the POWER button to turn on the SE-BAT system;
6. Put the small cover plate back;
7. Reinstall the upper cover board to SE-BAT-MA H 5.8;
8. Power on the Inverter.

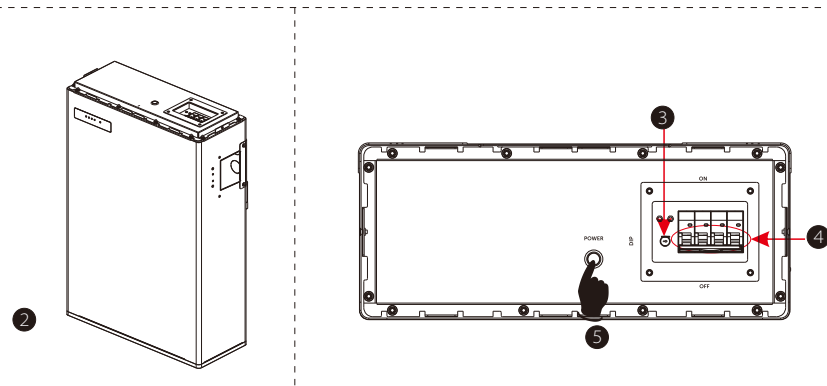
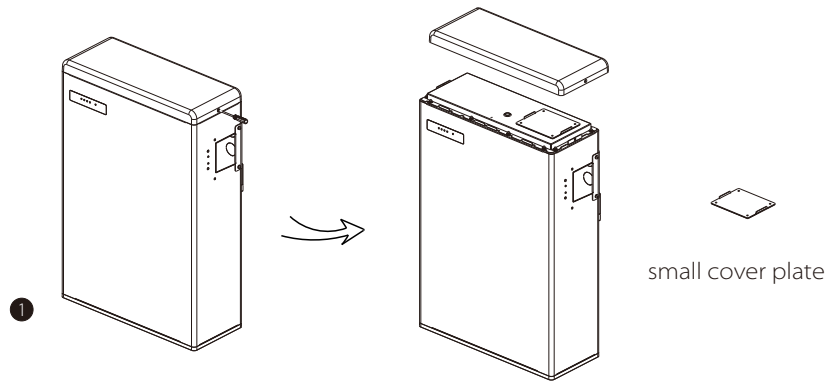

5.3 Status Indicators

The LED indicators on the front panel of the battery pack are showing the operating status.

5.3.1 BMS



The following table shows the status of BMS.

No.	Status of BMS	Mode
1	Light off	Power off
2	The Green LED is light on for 1s, and light off for 4s	Inverter sends Idle command
3	The Orange LED is light on for 1s, and light off for 4s	BMS Protection
4	The Red LED keeps light on for 10min, then flickers with light on for 1s, and light off for 4s	Fault
5	The Green LED is light on for 0.3s, and light off for 0.3s	Upgrade for BMS
6	The Green LED keeps light on	Active

The capacity indicators show the SOC:

- When the battery pack is neither charging nor discharging, the indicator lights off.
- When the battery pack is charging, part of the Blue LED is flashing with the frequency of light on for 0.5s, light off for 0.5s, and part of the Blue LED keeps light on. Take SOC 60% for instance, in charging state:
 1. The first two Blue LED indicators keeps on
 2. The third Blue LED indicator flashes once every 1s
- When the battery pack is discharging, the Blue LED is flashing with the frequency of light on for 1s, and light off for 4s. Take SOC 60% for instance, in discharging state:
 1. The first three blue LED indicators flash once every 5s



Charging

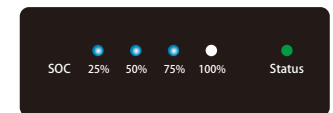

Discharging

5.3.2 Battery Pack

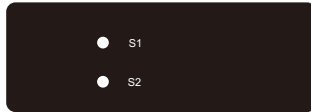

S1 and S2 represent independent status indicators. The status of S1 and S2 have the same meaning for battery pack in the following table.

Note: only when both S1 and S2 are flashing once every 5s in Green LED, it means the battery system is active.

No.	Status of battery pack	Mode
1	Light off	Power off/Sleep
2	The Green LED is light on for 1s, and light off for 4s	Active
3	The Orange LED is light on for 1s, and light off for 4s	Protection
4	The Red LED keeps light on for 10min, then flickers with light on for 1s, and light off for 4s	Fault
5	The Green LED is light on for 0.3s, and light off for 0.3s	Upgrade for BMS

NOTE!

After powering off the BMS, the LED lights of S1 and S2 will keep flashing in 20 minutes.

5.4 Shutting Down SE-BAT System

To shut down the system, follow the steps described below:

1. Turn off the breaker between Inverter and battery pack;
2. Open the upper cover board;
3. Power off the BMS;
4. Turn off the system by moving the circuit breaker switch to the OFF position;
5. Make sure that every indicator on the SE-BAT system is off;
6. Disconnect the cables.

6 Troubleshooting

6.1 Troubleshooting

Check the indicators on the front to determine the state of the SE-BAT system. A warning state is triggered when a condition, such as voltage or temperature is beyond the design limitations. The SE-BAT system's BMS periodically reports its operating state to the inverter.

When the SE-BAT system falls outside prescribed limits, it enters a warning state. When a warning is reported, the inverter immediately stops operation. Use the monitoring software on the inverter to identify what caused the warning. The possible warning messages are as follows:

Warning Messages	Description	Troubleshooting
BMS_External_Err	The communication between BMS and Inverter is interrupted	Check if the communication cable between BMS and Inverter is correctly and well connected.
BMS_Internal_Err	1. DIP switch at the wrong position; 2. The communication between battery packs is interrupted	1. Move the DIP switch to the correct position; 2. Check if the communication cable between battery packs is correctly and well connected.
BMS_OverVoltage	Battery over voltage	Please contact Solarever after-sales service or your distributor directly.
BMS_LowerVoltage	Battery under voltage	Please contact Solarever after-sales service or your distributor directly.
BMS_ChargeOCP	Battery charge over current protection	Please contact Solarever after-sales service or your distributor directly.
BMS_DischargeOCP	Battery discharge over current protection	Please contact Solarever after-sales service or your distributor directly.

Warning Messages	Description	Troubleshooting
BMS_TemHigh	Battery over temperature	Wait till the temperature of cells go back to the normal state.
BMS_TemLow	Battery under temperature	Wait till the temperature of cells go back to the normal state.
BMS_CellImblance	The capacities of cells are different	Please contact Solarever after-sales service or your distributor directly.
BMS_Hardware_Protect	Battery hardware under protection	Please contact Solarever after-sales service or your distributor directly.
BMS_Insulation_Fault	Battery insulation fault	Please contact Solarever after-sales service or your distributor directly.
BMS_VoltSensor_Fault	Battery voltage sensor fault	Please contact Solarever after-sales service or your distributor directly.
BMS_TempSensor_Fault	Battery temperature sensor fault	Please contact Solarever after-sales service or your distributor directly.
BMS_CurrSensor_Fault	Battery current sensor fault	Please contact Solarever after-sales service or your distributor directly.
BMS_Relay_Fault	Battery relay fault	1. Make sure the power cable is correctly and well connected to the power connector (XPLUG) of the BMS; 2. If the first step still does not work, please contact Solarever after-sales service or your distributor directly.
BMS_SelfChk_Fault	BMS selfcheck fault	Please contact Solarever after-sales service or your distributor directly.

Warning Messages	Description	Troubleshooting
BMS_CellTempDiff_Fault	The temperature between cells are different	Stop charging or discharging for a while.
BMS_CapMismatch_Fault	The capacity of battery packs are different	Please contact Solarever after-sales service or your distributor directly.
BMS_SlaveSwVer_Mismatch_Fault	The software between slavers are different	Please contact Solarever after-sales service or your distributor directly.
BMS_SlaveSw&HwMismatch_Fault	The hardware is different	Please contact Solarever after-sales service or your distributor directly.
BMS_Manu_Mismatch_Fault	The cell manufacture is different	Please contact Solarever after-sales service or your distributor directly.
BMS_MasterSw&SlaveSwMismatch_Fault	The software between Master and Slaver are different	Please contact Solarever after-sales service or your distributor directly.
BMS_ChgReqNoAck_Fault	No action for charging request	Check the information from Inverter.

7 Decommissioning

7.1 Dismantling the Battery

Shutting down SE-BAT system

Disconnect the cables between BMS and Inverter

Disconnect the series wiring terminal on the ended battery.

Disconnect the other cables.

7.2 Packing

Please pack the BMS and battery packs with the original packaging.

If it is no longer available, you can also use an equivalent carton that meets the following requirements.

- Suitable for loads more than 154. 32 lbs/70 kg
- With handle
- Can be fully closed

8 Maintenance and Warranty

8.1 Maintenance

If the ambient temperature for storage is $-4^{\circ}\text{F}\sim 131^{\circ}\text{F}/-20^{\circ}\text{C}\sim 55^{\circ}\text{C}$, recharge the batteries at least one time every 3 months.

If the ambient temperature for storage is $-4^{\circ}\text{F}\sim 68^{\circ}\text{F}/-20\sim 20^{\circ}\text{C}$, - recharge the batteries at least one time every 6 months.

8.2 Warranty

Solarever protects this product under warranty when it is installed and used as listed in this manual. Violation of installation procedure or use of the product in any way not described in this manual will immediately void all warranties on the product.

Solarever does not provide warranty coverage or assume any liability for direct or indirect damages or defects that result from the following causes:

- Force majeure (flooding, lightning strike, overvoltage, fire, thunderstorm, etc.)
- Improper or noncompliant use
- Improper installation, commissioning, start up or operation (contrary to the guidance detailed in the installation manual supplied with each product)
- Inadequate ventilation and circulation resulting in minimized cooling and natural air flow
- Installation in a corrosive environment
- Damage during transportation
- Unauthorized repair attempts
- Failure to adequately maintain the equipment. An on-site inspection by a qualified technician is possible following 120 months of continuous use. Warranty claims made beyond 120 months from date of commissioning may be declined if it cannot be demonstrated that the equipment has been adequately maintained
- External influence including unusual physical or electrical stress (power failure surges, inrush current, etc.)
- Use of an incompatible inverter or devices